

# ZEUS

35.10



*macchine edili ed agricole*  
**d DIECI**  
S.r.l.

# Zeus 35.10

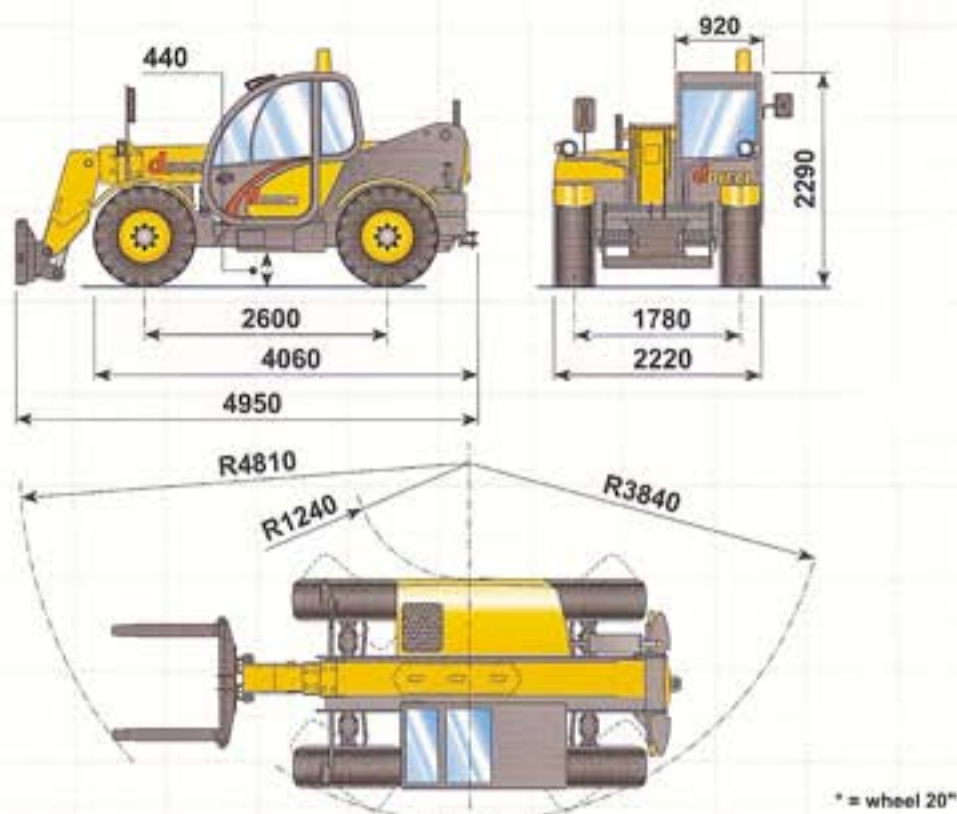
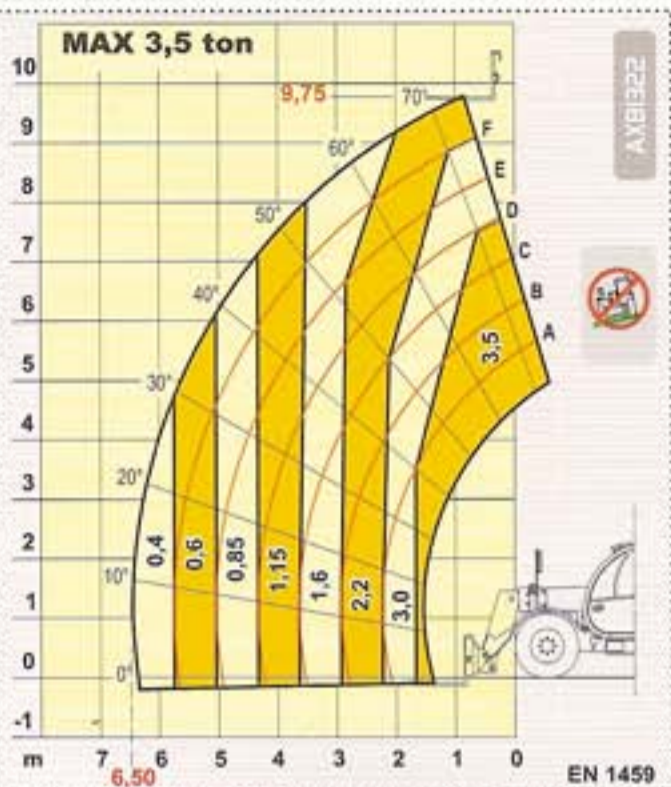

## PERFORMANCES

Maximum capacity:	3.500 kg
Capacity at maximum height on tyres:	2.200 kg
Capacity at maximum boom extension on tyres:	400 kg
Maximum lifting height on tyres:	9,75 m
Maximum horizontal boom extension:	6,50 m
Boom extension at maximum height:	0,84 m
Fork tilting angle:	130°
Tearing force:	5.700 daN
Towing force:	7.300 daN
Maximum allowable slope:	40 %
Total empty weight:	7.600 kg
Max speed:	30 km/h

(on request 40 km/h with TC and TA engine)



## TRANSMISSION

Transmission: hydrostatic with variable delivery pump  
 Hydraulic engine: with automatic adjustment  
 Reversing gear: electro - hydraulic  
 Inching pedal for controlled forward movement.  
 Servocontrolled 2 speed gearbox.



## HYDRAULIC SYSTEM

Gear pump with capacity at max speed: 100 l/1'  
 Max working pressure: 230 bar  
 Control valve with joystick: 3 in 1



## DIFFERENTIAL AXLES

Steering axles: 2, with planetary reduction gears  
 Type of steering: 4 wheels / transversal / 2 wheels  
 Front axle: rigid (levelling on request)  
 Rear axle: oscillating  
 Service brake: oil bath on the front axle with servo-brake  
 Negative parking brake



## ENGINE

**IVECO NEF F4GE0404A - NA - 60 kW ENGINE**  
 Maximum power: 60 kW (82 hp) at 2300 rpm  
 Operating principle: four-stroke, diesel engine  
 Cylinder number and layout: 4, vertical in line  
 Displacement: 4485 cm<sup>3</sup> - aspirated  
 Cooling system: liquid

**IVECO NEF F4GE0454A - TC - 74 kW ENGINE**  
 Maximum power: 74 kW (102 hp) at 2300 rpm  
 Operating principle: four-stroke, diesel engine  
 Cylinder number and layout: 4, vertical in line  
 Displacement: 4485 cm<sup>3</sup> - Turbo compressor  
 Cooling system: liquid

**IVECO NEF F4GE0484C - TA - 94 kW ENGINE**  
 Maximum power: 94 kW (128 hp) at 2300 rpm  
 Operating principle: four-stroke, diesel engine  
 Cylinder number and layout: 4, vertical in line  
 Displacement: 4485 cm<sup>3</sup> - Aftercooler turbo compressor  
 Cooling system: liquid



## REFUELLING (litre)

Hydraulic tank: 140  
 Fuel tank: 95



## STANDARD DEVICES

Anti-tipping device with block for hazardous movements.  
 Hydraulic socket for possible accessories on boom head.  
 Closed soundproof ROPS - FOPS approved driver's cab, with heating.  
 Self-locking differential on front axle (limited slip 45%).



## TYRES

Tyres: 16/70x20" MPT04  
 Alternative: 405/70x24" MPT04



## OPTIONAL AND ACCESSORIES

Optional and Accessories: see the relevant catalogue

The information contained in this publication is merely indicative; the models described may be modified, without notice, by the manufacturer. Drawings and photographs may refer to optional or particular equipment for other countries. For any further information, please contact DIECI premises at the address given below.

(Cod. AXE3070 - 06/2004 v2 - ING)

**DIECI S.r.l.**  
 Via E. Majorana, 2-4 - 42027 Montecchio Emilia (RE)  
 Tel. +39 0522 869611 - Fax +39 0522 869744  
 www.dieci.com - mailbox@dieci.com

macchine edili ed agricole  
**d DIECI**